

# THR<sup>®</sup> V<sup>®</sup> joist<sup>®</sup>

## DOUBLE JOIST OPTION

**NEW  
PRODUCT**

### FIXING NOTE

1. Bracket needs to be installed firmly up against under side of joist and all holes nailed off before drilling service duct hole.
2. Galv Bracket 30mm x 3.15 dia hot dip galvanised nails to be used in NZ.
3. Galv Bracket 35mm x 3.15 dia hot dip galvanised nails to be used in Australia.
4. Nail ALL holes.
5. Maximum hole cut is 121mm dia in 190mm, 240 and 290mm THRU-JOIST<sup>®</sup> or 68mm dia in 140mm THRU-JOIST<sup>®</sup> brackets.
6. Use TJD140 on 140mm joist, TJD190 on 190mm, TJD240 on 240mm and TJ D290 on the 290mm joist.
7. Obtain fall for plumbing pipes by drilling holes at varying heights, within drilling circle, on adjacent joists.
8. No limitation on where THRU-JOIST<sup>®</sup> brackets may be installed along the length of joist.
9. Use of multiple brackets on one joist must have minimum of 1500mm spacing between centres.
10. NOT TO BE USED IN EXTERIOR OR SUB FLOOR SITUATIONS.
11. Nails are not provided.
12. The purchaser is responsible for checking that THRU-JOIST<sup>®</sup> brackets are suitable for its intended use.

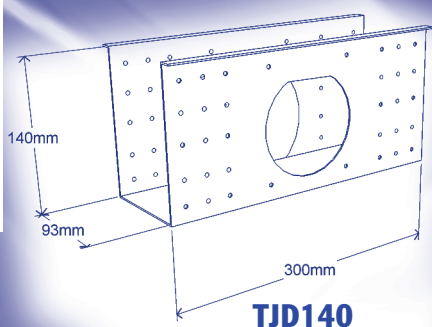

**TJD140**  
(for 140 x 90mm joist)

#### NZ Reg. Designs

410058  
410059  
410060  
410061

#### Aust. Reg Designs

318486  
318487  
318488  
318489

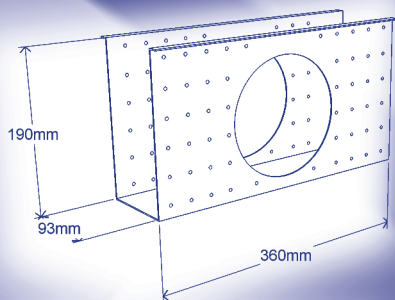

**TJD190**  
(for 190 x 90mm joist)

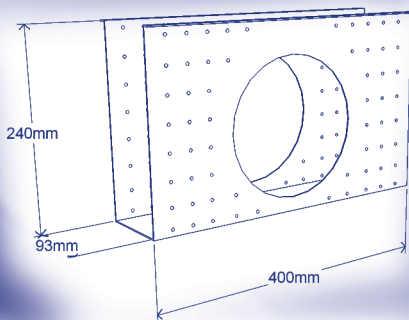

**TJD240**  
(for 240 x 90mm joist)

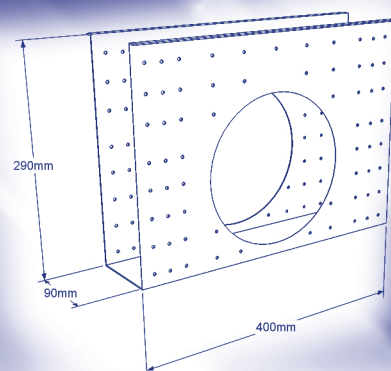

**TJD290**  
(for 290 X 90mm joist)

The full range of brackets is available from leading building and plumbing supply merchants.

Designed and Marketed by BRACE-IT LIMITED, PO BOX 558, Whangaparaoa, Auckland 0943 NZ.

Phone **+64 9 424 0916**

Fax **+64 9 424 0475**

email [info@brace-it.com](mailto:info@brace-it.com)

Copyright©2007/2017 Brace-It™ Limited. All rights reserved.

No copying, distribution or other use of this work is permitted without the express written consent of Brace-It™ Limited. Version 2 - 1/12/2016.